

Mounting bracket with gasket CRDG



Description

The "CRDG" clamp consists of two components connected by steel bolts. Up to and including a diameter of 450 mm, only one side is self-clamping, thereby clamp assembly on ventilation ducts is facilitated. In this diameter range fastening clamp is mounted to threaded rod or to double-threaded bolt through rivet nuts M8/M10. For reasons of assembly safety, clamps with diameters from 500 mm should be mounted through two threaded rods. Fastening clamps "CRDG" are, as a standard, equipped with a rubber gasket EPDM with the option of removal.

Technical drawing

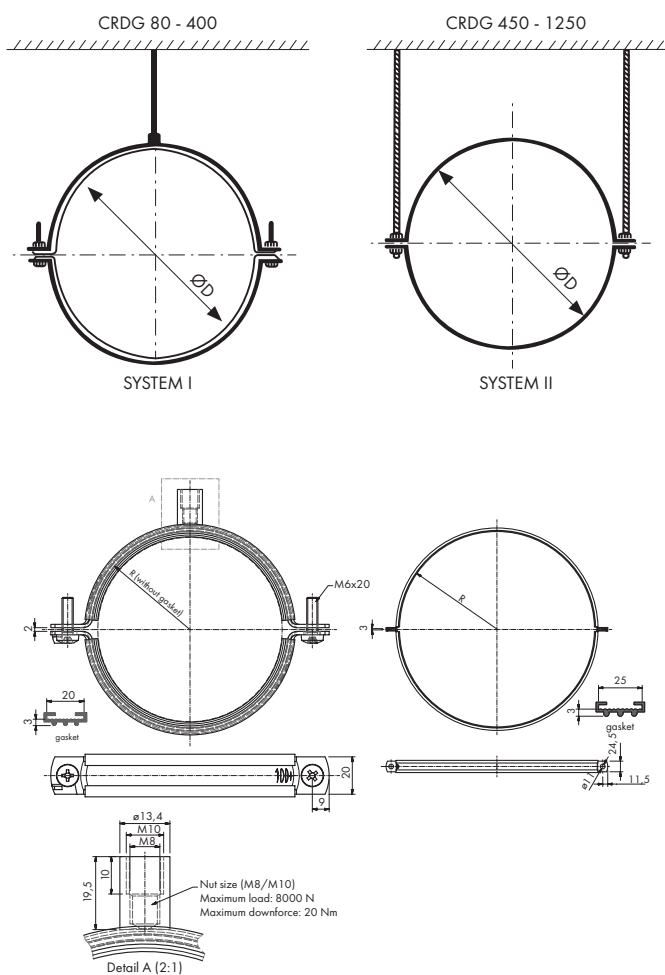

Dimensions [mm]

Model	ØD	System
CRDG 80	80	I
CRDG 100	100	I
CRDG 125	125	I
CRDG 150	150	I
CRDG 160	160	I
CRDG 200	200	I
CRDG 250	250	I
CRDG 315	315	I
CRDG 400	400	I
CRDG 450	450	II
CRDG 500	500	II
CRDG 560	560	II
CRDG 630	630	II
CRDG 710	710	II
CRDG 800	800	II
CRDG 900	900	II
CRDG 1000	1000	II
CRDG 1250	1250	II