

## Single blade damper with gasket DSCX



Rounded, reinforced  
"SAFE" edges



Double gasket,  
tightness class D



Automatic linear  
welding



Top quality  
galvanised steel  
275 g/m<sup>2</sup>

### Description

Single blade regulating damper with gasket - DSCX, made from top quality galvanised steel (275 g/m<sup>2</sup>). Fully automated linear welding process. With every edge "SAFE" type - reinforced with curved rims, provide additional fitting rigidity and safe mounting. Double gasket EPDM clamped automatically ensures no risk of slipping during mounting. Product with tightness class D - every single bend undergoes air tightness test in the factory.

### Technical drawing

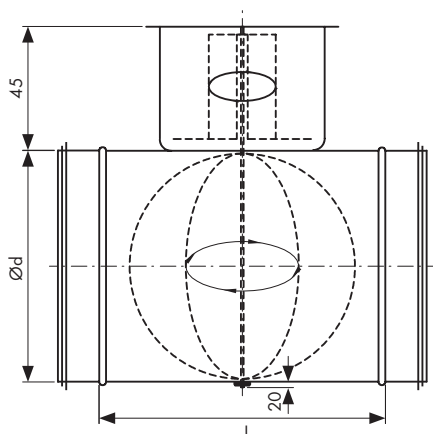

### Dimensions [mm]

Ød nom	L	kg	pcs/box	box type
80	90	0,34		on request
100	90	0,39	40	P6
125	90	0,43	27	P6
150	90	0,60	30	P4
160	90	0,66	27	P4
200	90	0,80	36	P2
250	90	1,30	36	P1
315	90	1,77	28	P1
355	90	2,05	20	P1
400	90	2,85	15	P1
450	90	2,85	10	P1
500	90	3,51	4	P2
560	90	4,26	5	P1
630	90	5,2	4	P1
710	90	5,83	-	-
800	90	6,86	-	-
900	90	9,5	-	-
1000	90	10,84	-	-



Packaging method on page 38