

# PPU-LCHX

**Pipework package unit for liquid coupled heat exchanger**

## CONTENT

<b>1. INTRODUCTION</b> .....	3
<b>2. ENCODING AND CONSTRUCTION</b> .....	3
<b>3. MECHANICAL INSTALLATION</b> .....	4
<b>4. ELECTRICAL INSTALLATION</b> .....	5
<b>5. FLOW RATE REGULATION</b> .....	7
<b>6. PERIODICAL MAINTENANCE</b> .....	10
<b>7. TECHNICAL DATA</b> .....	10

## 1. INTRODUCTION

This manual is intended for qualified technicians installing pipework package unit (PPU) for liquid coupled heat exchanger. Qualified professionals are persons with sufficient professional experience and knowledge of plumbing systems for heating/cooling, their installation, knowledge of electrical safety requirements and ability to work without risk to themselves or others.

To avoid misunderstandings, read this manual carefully before installing the PPU, since ignoring the instructions not only shall invalidate the manufacturer's warranty but can also cause direct damage to property or human health.



- When performing installation works, make sure the frequency inverter and circulation pump are unplugged from electrical supply. Do not connect them to electrical power until all mechanical works on PPU are finished.
- Use caution when working near internal or external heaters of the airhandling unit (AHU), as their surfaces may be hot.
- Do not connect frequency inverter and circulation pump to the power supply network if there is visible damage that occurred during transportation.
- Use appropriate personal protective equipment (gloves, goggles) when installing or repairing the PPU.



This sign means that the product may not be disposed of together with your household waste as defined in Directive (2002/96/EC) and national legislation on the management of WEEE. This product must be disposed of at an appropriate collection point or recycling facility for waste electrical and electronic equipment (WEEE). Improper handling of this type of waste due to hazardous substances inside electrical and electronic equipment can endanger the environment and human health. By helping to ensure proper disposal of this product, you will also contribute to the efficient use of natural resources. For more information on how to dispose of such waste for further recycling, contact your city authorities, waste management organisations, approved WEEE systems or your household waste management bodies representatives.

## 2. ENCODING AND CONSTRUCTION

PPU-LCHX is a pipework package unit for liquid coupled heat exchangers that are used for heat/cold recovery in the air handling units (AHU). PPU ensures proper circulation of thermal medium (usually mixture of glycol and water) throughout the piping circuit, regulates recuperation efficiency and prevents coils from freezing.

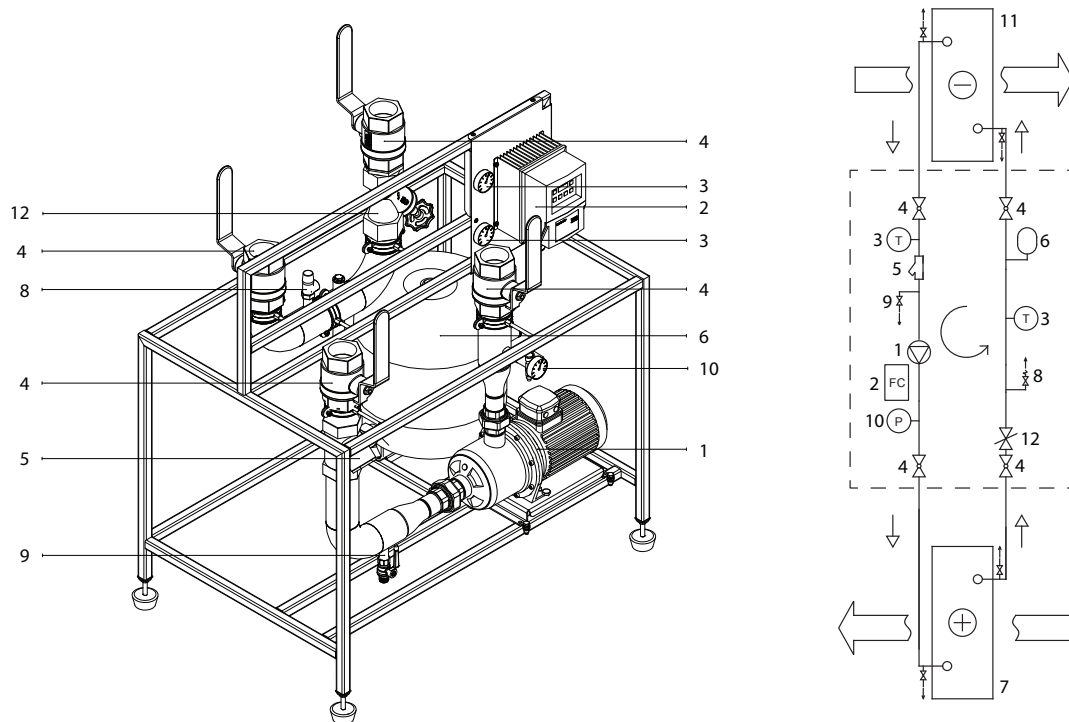

**Fig. 1.** PPU components and hydraulic diagram

1 – Circulation pump; 2 – Frequency inverter; 3 – Thermometer; 4 – Ball valve; 5 – Water filter; 6 – Expansion vessel; 7 – Coil in the supply airflow; 8 – Safety valve; 9 – Drain valve; 10 – Manometer; 11 – Coil in the extract airflow; 12 – Balancing valve

Encoding:

PPU	-	LCHX	-	FQ	-	L/R	-	40	-	WG2
1		2		3		4		5		6

1. PPU – Pipework package unit
2. LCHX – Liquid coupled heat exchanger
3. FQ – with frequency inverter
4. L/R – suitable for right (R) and left (L) inspection side AHU's
5. Connection pipe diameter (DN)
6. Type of circulation pump

### 3. MECHANICAL INSTALLATION

PPU-LCHX to be installed in technical room, where ambient temperature is 0..+40°C. Unit must be mounted on a flat and sturdy base or on a construction specially designed for mounting. If mounting base ins not flat, PPU can be leveled using adjustable feet at the bottom of the frame.



When selecting mounting location, you must foresee sufficient and secure access space for repair and maintenance operations. Also make sure PPU is not blocking access to the AHU and it's door can open freely.



Connect PPU to the heat exchanger coils of the AHU, following hydraulic diagram (see Fig. 1). It is important to ensure that fluid flow direction (marked on the arrow stickers of the PPU) is correct. For effective operation of liquid coupled heat exchanger, thermal medium flow direction should be against airflow direction. When fully assembled, all hydraulic circuit must be filled with glycol (not more than 40%) and water mixture. Pipes are filled through the drain valve until static pressure of 1.5 bar is reached. Do not use circulation pump of the PPU for filling the pipes – additional equipment or pump must be used.



All piping between PPU and AHU coils should be thermally insulated after the works.



## 4. ELECTRICAL INSTALLATION

Electrical work may only be carried out by a qualified electrician in accordance with the instructions given in this manual and in accordance with applicable legal requirements and safety requirements. Before performing electrical component installation:



- Check there is no mechanical damage on frequency inverter or circulation pump.
- Check the insulation of the cable between frequency inverter and circulation pump is not damaged.
- Locate user manual for the frequency inverter.
- If the PPU has been standing in an unheated room for a long time, make sure that electronic parts and cable connectors were not affected by moisture.



Configure micro-switches, connect electrical power and control cables to the frequency inverter (see Fig. 2):

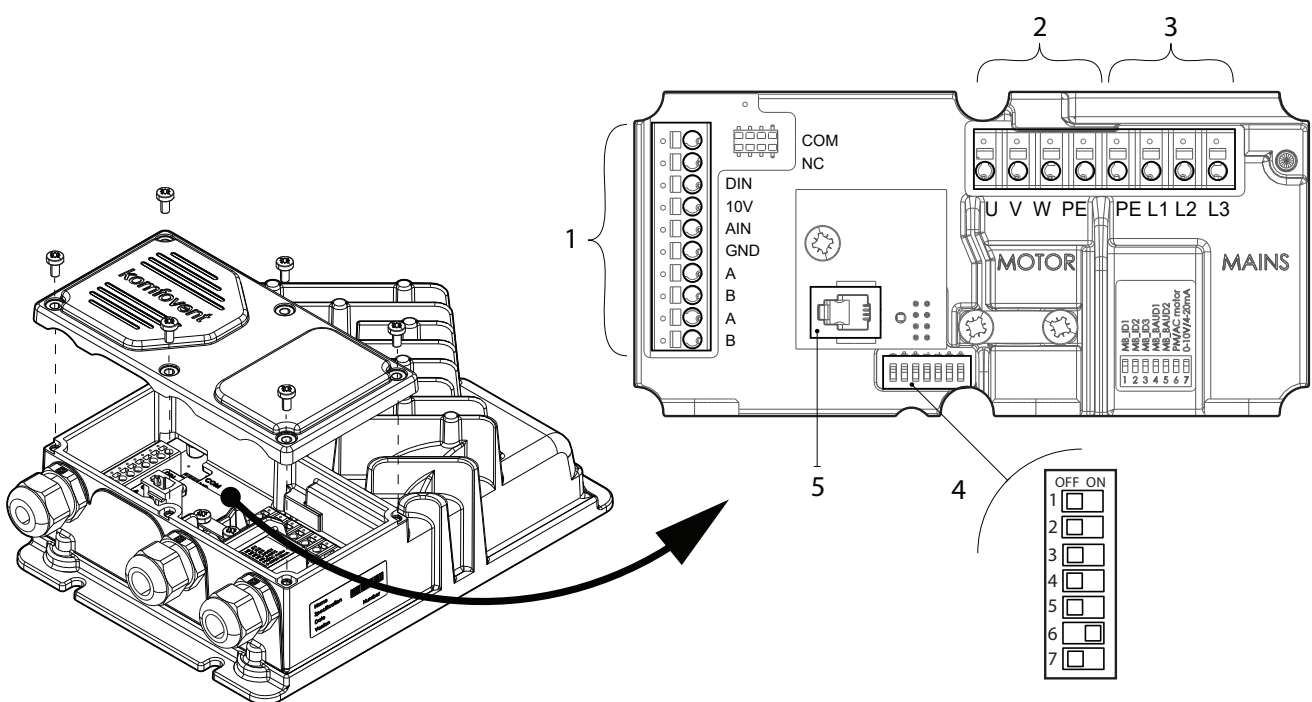

**Fig 2.** Frequency inverter

- 1 – Frequency inverter control terminals, 2 – Pump connection terminals, 3 – Main power terminals  
 4 – Micro switch configuration, 5 – Control panel connection (RJ9)

- Terminals **L1, L2, L3, PE** are for 3x400 V AC, 50 Hz electrical power connection. Connect power cable to the mains via 10A automatic circuit breaker (type C).
- Terminals **DIN and 10V** are for inverter start/stop signal (open/close contact). If such signal is not needed, wire link must be installed instead.
- Terminals **AIN and GND** is for inverter control signal (0..10V).

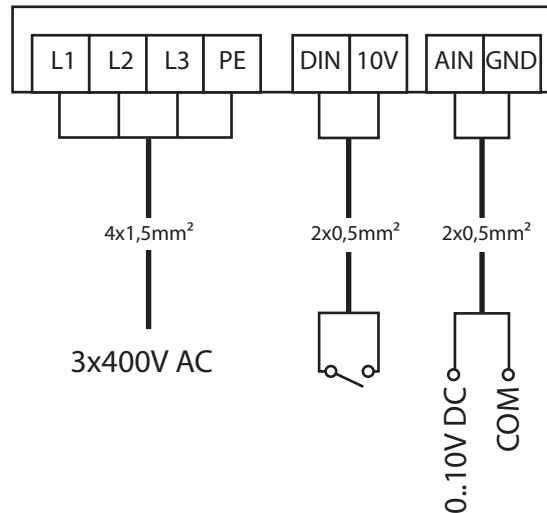

**Fig. 3.** Frequency inverter connection diagram



- Connect the frequency inverter only to suitable power socket with appropriate earthing and meeting the electrical safety requirements.
- For information on how to connect frequency converter to the AHU automation control, please follow electrical wiring diagram of the AHU.



## 5. FLOW RATE REGULATION

For circulation pump to run correctly, it is needed to set PPU flow rate according to designed flow rate stated in the technical printout of the liquid coupled heat exchanger. Flow rate of the PPU is set as follows:

1. Fully open balancing valve.
2. Connect differential pressure measuring equipment to the pressure measuring ports of the balancing valve.
3. Using flow rate diagram (Fig. 4), determine which differential pressure should be achieved, for PPU to reach the designed flow rate.

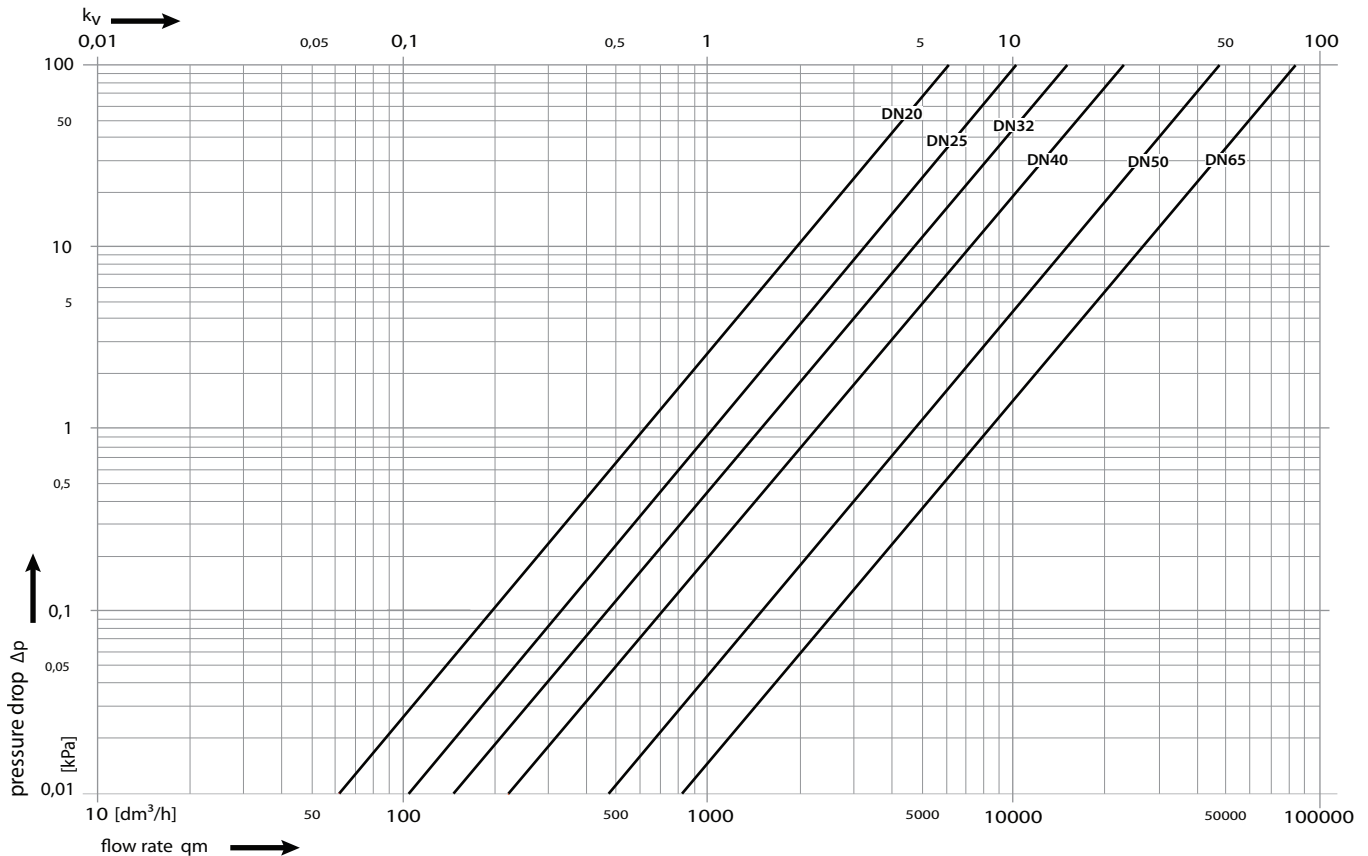

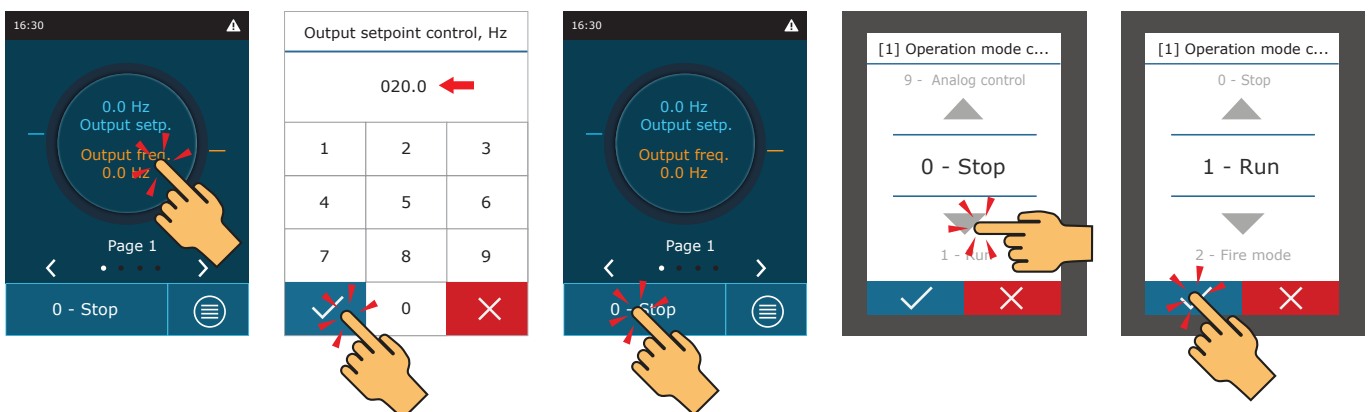

Fig. 4. Flow rate diagram of the balancing valves

4. Connect control panel of frequency inverter (see Fig. 2).

 It is mandatory to turn OFF main power of the inverter, when connecting or disconnecting control panel cable, otherwise panel will be damaged. 

5. Turn ON power of the inverter. Set initial frequency using control panel (20 Hz recommended) and start the inverter:



6. By increasing/decreasing inverter frequency, regulate pump speed until correct differential pressure will be reached. Memorize or write down operating frequency of the inverter at this pressure point.

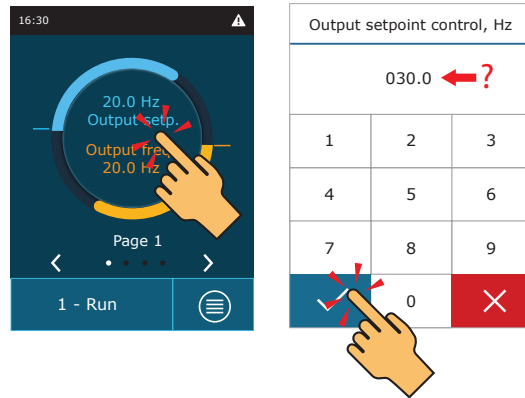

7. Stop the inverter:

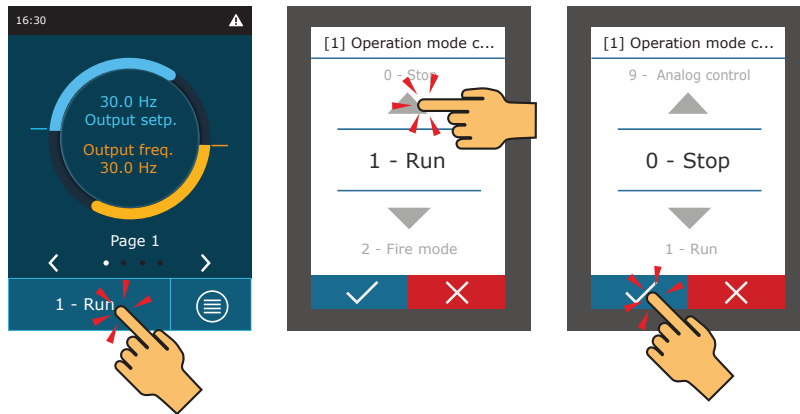

8. Enter to the parameter **102** same frequency, under which correct differential pressure was reached (according step 6).

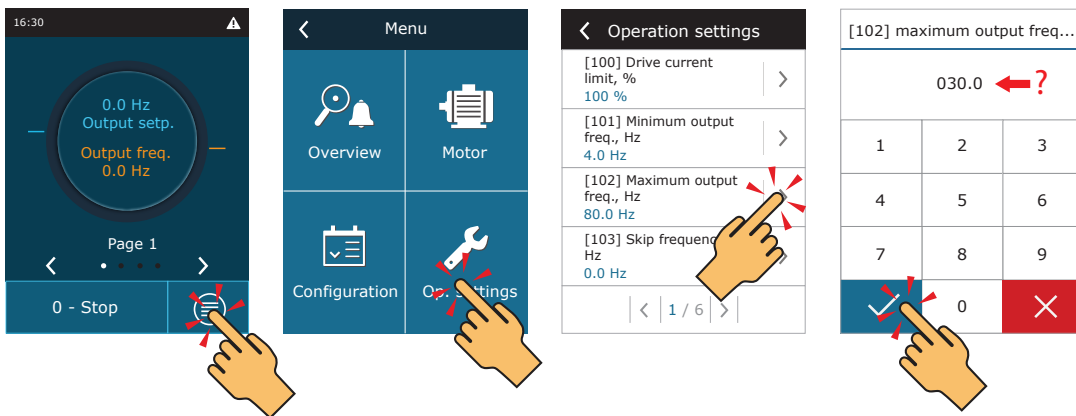



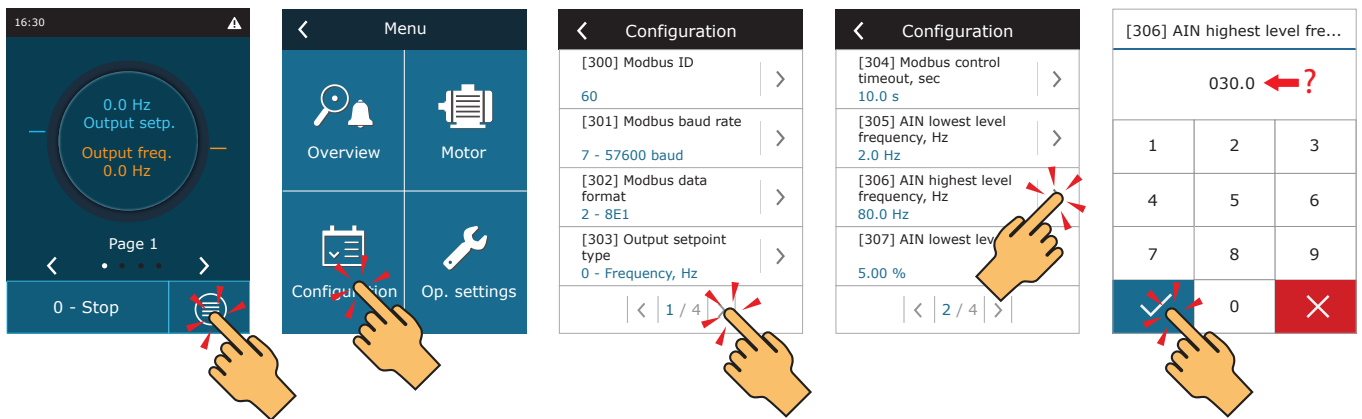

9. Enter to the parameter **306** same frequency, under which correct differential pressure was reached (according step 6).



10. Turn OFF power of the inverter. If control panel will not be used, disconnect it from the inverter. Also disconnect control panel in case if PPU is mounted in the unheated room..

 It is mandatory to turn OFF main power of the inverter, when connecting or disconnecting control panel cable, otherwise panel will be damaged. 

11. Turn ON main power of the inverter and start AHU. Check operation of the liquid coupled heat exchanger and PPU-LCHX.

## 6. PERIODICAL MAINTENANCE



- Before starting any maintenance works, make sure that PPU and AHU are stopped.
- If there is a need to perform any mechanical works on the piping circuit (for example to tighten couplings or to clean water filter and etc.) disconnect PPU and AHU from the mains power.



It is recommended to carry out PPU-LCHX periodical maintenance at least once a year. If needed register performed works in the maintenance log.

Following to be checked during maintenance:

- Piping circuit is tight, there are no leakage marks.
- Circulation pump operates correctly. There are no big vibrations or unnecessary noise.
- There are no alarms on the frequency inverter.
- Signal and power cables are in good condition, there are no corrosion marks on the connectors and electrical terminals.
- Measuring tools (manometer, thermometers) operates correctly.
- Water filter is not clogged (clean the filter if necessary).

## 7. TECHNICAL DATA

Pipework package unit model	Filter and balancing valve	Pipe connections		Pump type	Pump power kW	Frequency inverter	Dimensions of the PPU frame (excluding adjustable feet)			Expansion vessel volume Liters	PPU weight kg
		DN	inch				B, mm	H, mm	L, mm		
PPU-LCHX-FQ-L/R-20-WG1	DN20	20	3/4"	WG1	0,55	DF2-551M0	500	867,5	650	5	45
PPU-LCHX-FQ-L/R-20-WG2	DN20	20	3/4"	WG2	0,55	DF2-551M0	500	867,5	650	5	42
PPU-LCHX-FQ-L/R-25-WG1	DN25	25	1"	WG1	0,55	DF2-551M0	500	867,5	650	8	46
PPU-LCHX-FQ-L/R-25-WG2	DN25	25	1"	WG2	0,55	DF2-551M0	500	867,5	650	8	43
PPU-LCHX-FQ-L/R-32-WG2	DN32	32	1 1/4"	WG2	0,55	DF2-551M0	550	867,5	700	12	47
PPU-LCHX-FQ-L/R-40-WG2	DN40	40	1 1/2"	WG2	0,55	DF2-551M0	550	1037,5	850	18	60
PPU-LCHX-FQ-L/R-40-WG3	DN40	40	1 1/2"	WG3	1,1	DF2-112M0	550	1037,5	850	18	65
PPU-LCHX-FQ-L/R-50-WG3	DN50	50	2"	WG3	1,1	DF2-112M0	550	1037,5	900	24	71
PPU-LCHX-FQ-L/R-50-WG4	DN50	50	2"	WG4	2,2	DF2-222S0	550	1037,5	900	24	78
PPU-LCHX-FQ-L/R-65-WG3	DN65	65	2 1/2"	WG3	1,1	DF2-112M0	670	1037,5	1000	30	75
PPU-LCHX-FQ-L/R-65-WG4	DN65	65	2 1/2"	WG4	2,2	DF2-222S0	670	1037,5	1000	30	82

**DN20-DN32**

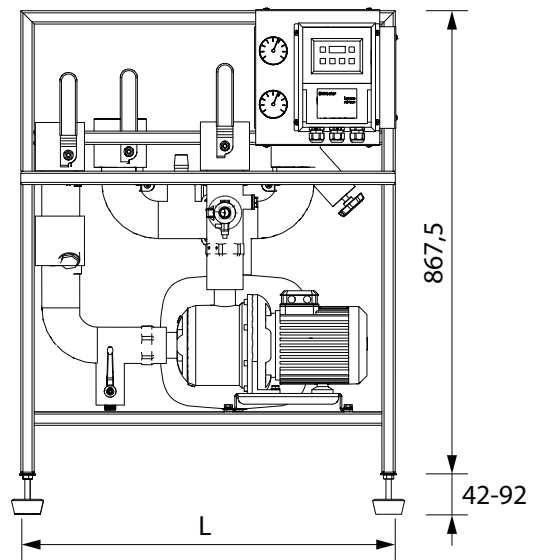
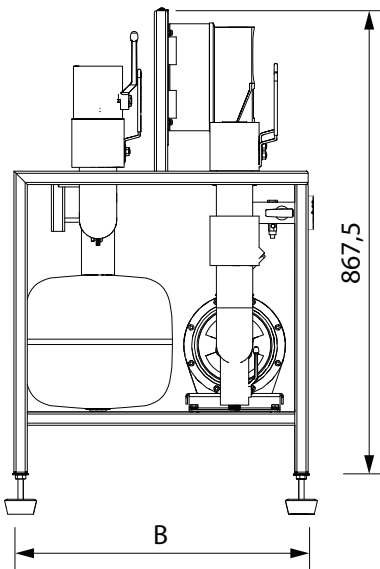

**DN40-DN65**

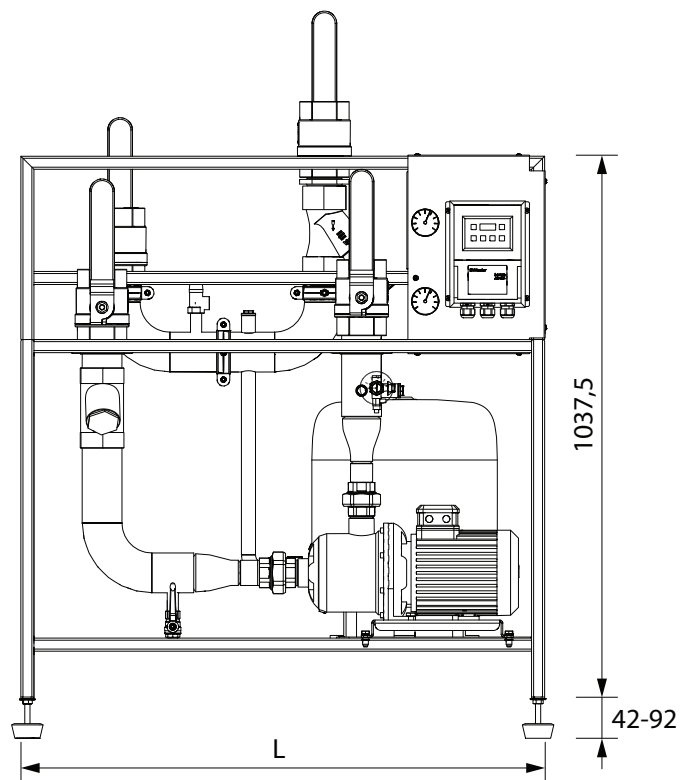
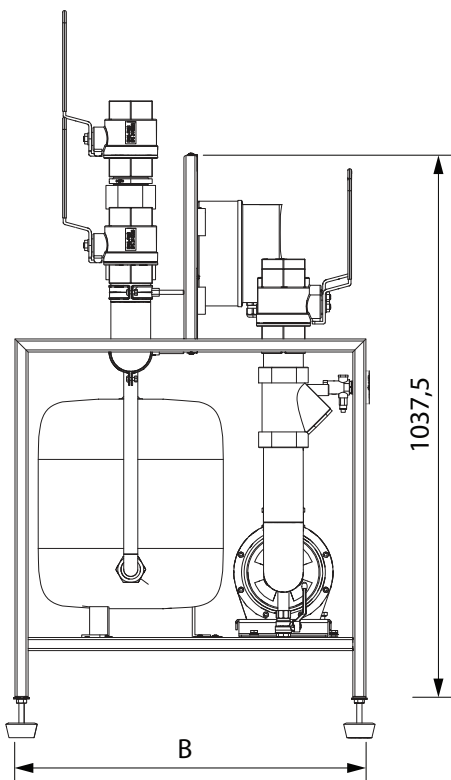

## LITHUANIA

### UAB KOMFOVENT

#### TECHNINĖS PRIEŽIŪROS SKYRIUS / SERVICE AND SUPPORT

Phone: +370 5 200 8000  
Email: [service@komfovent.com](mailto:service@komfovent.com)  
[www.komfovent.com](http://www.komfovent.com)

## RUSSIA

### ООО «КОМФОВЕНТ»

Ул. Выборгская д. 16, стр. 1,  
2 этаж, 206 офис, Москва, Россия  
Тел. +7 499 673 22 73  
[info.ru@komfovent.com](mailto:info.ru@komfovent.com)  
[www.komfovent.ru](http://www.komfovent.ru)

### ООО «КОМФОВЕНТ»

Ряжское шоссе, 20 литера Е, пом Н6  
390017 г. Рязань, Россия  
Тел.: +7 491 255 95 71  
[info.ru@komfovent.com](mailto:info.ru@komfovent.com)  
[www.komfovent.ru](http://www.komfovent.ru)

## BELARUS

### ИООО «Комфобент»

ул. Уручская 21 – 423,  
220125 г. Минск, Беларусь  
Тел. +375 17 266 5297, 266 6327  
[info.by@komfovent.com](mailto:info.by@komfovent.com)  
[www.komfovent.by](http://www.komfovent.by)

## SWEDEN

### Komfovent AB

Ögärdesvägen 12B  
433 30 Partille, Sverige  
Tel. +46 31 487 752  
[info\\_se@komfovent.com](mailto:info_se@komfovent.com)  
[www.komfovent.se](http://www.komfovent.se)

## FINLAND

### Komfovent Oy

Muuntotie 1 C1  
FI-01 510 Vantaa, Finland  
Tel. +358 0 408 263 500  
[info\\_fi@komfovent.com](mailto:info_fi@komfovent.com)  
[www.komfovent.com](http://www.komfovent.com)

## PARTNERS

AT	J. PICHLER Gesellschaft m. b. H.	<a href="http://www.pichlerluft.at">www.pichlerluft.at</a>
BE	Ventilair group	<a href="http://www.ventilairgroup.com">www.ventilairgroup.com</a>
	ACB Airconditioning	<a href="http://www.acbairco.be">www.acbairco.be</a>
CZ	REKUVENT s.r.o.	<a href="http://www.rekuvent.cz">www.rekuvent.cz</a>
	WESCO AG	<a href="http://www.wesco.ch">www.wesco.ch</a>
CH	SUDCLIMATAIR SA	<a href="http://www.sudclimatair.ch">www.sudclimatair.ch</a>
	CLIMAIR GmbH	<a href="http://www.climair.ch">www.climair.ch</a>
DK	Øland A/S	<a href="http://www.oeland.dk">www.oeland.dk</a>
EE	BVT Partners	<a href="http://www.bvtpartners.ee">www.bvtpartners.ee</a>
FR	ATIB	<a href="http://www.atib.fr">www.atib.fr</a>
HR	Microclima	<a href="http://www.microclima.hr">www.microclima.hr</a>
	AIRVENT Légtechnikai Zrt.	<a href="http://www.airvent.hu">www.airvent.hu</a>
HU	Gevent Magyarország Kft.	<a href="http://www.gevent.hu">www.gevent.hu</a>
	Merkapt	<a href="http://www.merkapt.hu">www.merkapt.hu</a>
IR	Fantech Ventilation Ltd	<a href="http://www.fantech.ie">www.fantech.ie</a>
IS	Blikk & Tækniþjónustan ehf	<a href="http://www.bogt.is">www.bogt.is</a>
	Hitataekni ehf	<a href="http://www.hitataekni.is">www.hitataekni.is</a>
IT	Icaria srl	<a href="http://www.icariavmc.it">www.icariavmc.it</a>
	Ventilair group	<a href="http://www.ventilairgroup.com">www.ventilairgroup.com</a>
NL	DECIPOLE-Vortvent	<a href="http://www.vortvent.nl">www.vortvent.nl</a>
	CLIMA DIRECT BV	<a href="http://www.climadirect.com">www.climadirect.com</a>
NO	Ventilution AS	<a href="http://www.ventilution.no">www.ventilution.no</a>
	Ventistål AS	<a href="http://www.ventistal.no">www.ventistal.no</a>
PL	Thermo Control AS	<a href="http://www.thermocontrol.no">www.thermocontrol.no</a>
	Ventia Sp. z o.o.	<a href="http://www.ventia.pl">www.ventia.pl</a>
SE	Nordisk Ventilator AB	<a href="http://www.nordiskventilator.se">www.nordiskventilator.se</a>
SI	Agregat d.o.o	<a href="http://www.agregat.si">www.agregat.si</a>
SK	TZB produkt, s.r.o.	<a href="http://www.tzbprodukt.sk">www.tzbprodukt.sk</a>

## GERMANY

### Komfovent GmbH

Konrad-Zuse-Str. 2a,  
42551 Velbert, Deutschland  
Tel. +49 0 2051 6051180  
[info@komfovent.de](mailto:info@komfovent.de)  
[www.komfovent.de](http://www.komfovent.de)

## LATVIA

### SIA Komfovent

Bukaišu iela 1, LV-1004 Rīga, Latvia  
Tel. +371 24 66 4433  
[info@komfovent.lv](mailto:info@komfovent.lv)  
[www.komfovent.lv](http://www.komfovent.lv)

### Vidzemes filiāle

Alejas iela 12A, LV-4219 Valmiermuiža,  
Valmieras pagasts, Burtnieku novads  
Tel. +371 29 358 145  
[kristaps.zaicevs@komfovent.com](mailto:kristaps.zaicevs@komfovent.com)  
[www.komfovent.lv](http://www.komfovent.lv)